

PRIOR TO INSTALLATION check fit of cover gasket and oil pan segment(s). If necessary trim bottom ends of cover gasket and oil pan segment(s), flush with castings. Make certain to align the gasket holes with the casting holes.

ATTACH AND ALIGN GASKET AND SEGMENT(S): Apply a quick-drying adhesive sparingly in several places on the engine casting or block. Attach gasket(s) on surface where adhesive was applied. **Allow time for adhesive to set.** Test for slippage with light pressure. If gasket moves, allow more time.

ATTACH AND ALIGN OIL PAN END SEAL.

PRIOR TO REINSTALLING COVER: Apply a 1/8" bead of silicone sealer to the oil pan to block and seal to segment(s) intersections.

REINSTALL COVER TO ENGINE. Torque bolts evenly and slowly to OEM specifications.

TEST RUN ENGINE. Check all mating areas thoroughly to determine that all seals hold during operation.



FEL-PRO INSTALLATION TIPS

TIMING COVER

PRIOR TO INSTALLING THE SEAL apply a thin coat grease on the seal face.

IMPORTANT: Do not install any seal without break-in lubricant protection.

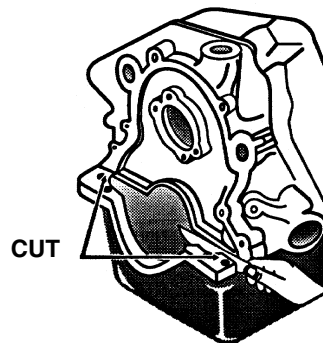

AFTER REMOVING TIMING COVER, CUT EXPOSED ENDS of the oil pan gasket flush with the cylinder block using a sharp blade, remove front oil pan end seal.

CLEAN MATING SURFACES of all foreign material including old gaskets, RTV and oil. You may wish to use a degreaser.

PRIOR TO INSTALLATION check fit of cover gasket and oil pan segment(s). If necessary trim bottom ends of cover gasket and oil pan segment(s), flush with castings. Make certain to align the gasket holes with the casting holes.

ATTACH AND ALIGN GASKET AND SEGMENT(S): Apply a quick-drying adhesive sparingly in several places on the engine casting or block. Attach gasket(s) on surface where adhesive was applied. **Allow time for adhesive to set.** Test for slippage with light pressure. If gasket moves, allow more time.

ATTACH AND ALIGN OIL PAN END SEAL.

PRIOR TO REINSTALLING COVER: Apply a 1/8" bead of silicone sealer to the oil pan to block and seal to segment(s) intersections.

REINSTALL COVER TO ENGINE. Torque bolts evenly and slowly to OEM specifications.

TEST RUN ENGINE. Check all mating areas thoroughly to determine that all seals hold during operation.



FEL-PRO INSTALLATION TIPS

TIMING COVER

PRIOR TO INSTALLING THE SEAL apply a thin coat grease on the seal face.

IMPORTANT: Do not install any seal without break-in lubricant protection.

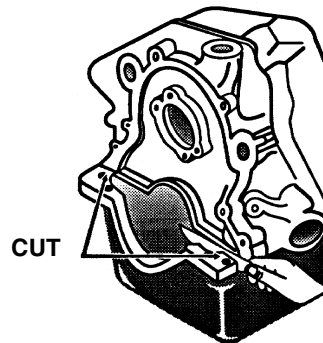

AFTER REMOVING TIMING COVER, CUT EXPOSED ENDS of the oil pan gasket flush with the cylinder block using a sharp blade, remove front oil pan end seal.

CLEAN MATING SURFACES of all foreign material including old gaskets, RTV and oil. You may wish to use a degreaser.

PRIOR TO INSTALLATION check fit of cover gasket and oil pan segment(s). If necessary trim bottom ends of cover gasket and oil pan segment(s), flush with castings. Make certain to align the gasket holes with the casting holes.

ATTACH AND ALIGN GASKET AND SEGMENT(S): Apply a quick-drying adhesive sparingly in several places on the engine casting or block. Attach gasket(s) on surface where adhesive was applied. **Allow time for adhesive to set.** Test for slippage with light pressure. If gasket moves, allow more time.

ATTACH AND ALIGN OIL PAN END SEAL.

PRIOR TO REINSTALLING COVER: Apply a 1/8" bead of silicone sealer to the oil pan to block and seal to segment(s) intersections.

REINSTALL COVER TO ENGINE. Torque bolts evenly and slowly to OEM specifications.

TEST RUN ENGINE. Check all mating areas thoroughly to determine that all seals hold during operation.



FEL-PRO INSTALLATION TIPS

TIMING COVER

PRIOR TO INSTALLING THE SEAL apply a thin coat grease on the seal face.

IMPORTANT: Do not install any seal without break-in lubricant protection.

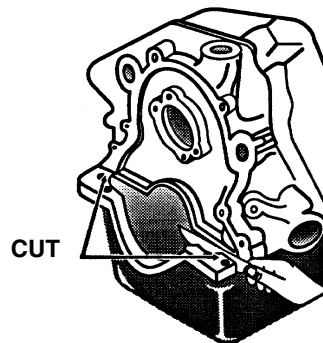

AFTER REMOVING TIMING COVER, CUT EXPOSED ENDS of the oil pan gasket flush with the cylinder block using a sharp blade, remove front oil pan end seal.

CLEAN MATING SURFACES of all foreign material including old gaskets, RTV and oil. You may wish to use a degreaser.

PRIOR TO INSTALLATION check fit of cover gasket and oil pan segment(s). If necessary trim bottom ends of cover gasket and oil pan segment(s), flush with castings. Make certain to align the gasket holes with the casting holes.

ATTACH AND ALIGN GASKET AND SEGMENT(S): Apply a quick-drying adhesive sparingly in several places on the engine casting or block. Attach gasket(s) on surface where adhesive was applied. **Allow time for adhesive to set.** Test for slippage with light pressure. If gasket moves, allow more time.

ATTACH AND ALIGN OIL PAN END SEAL.

PRIOR TO REINSTALLING COVER: Apply a 1/8" bead of silicone sealer to the oil pan to block and seal to segment(s) intersections.

REINSTALL COVER TO ENGINE. Torque bolts evenly and slowly to OEM specifications.

TEST RUN ENGINE. Check all mating areas thoroughly to determine that all seals hold during operation.



FEL-PRO INSTALLATION TIPS

TIMING COVER

PRIOR TO INSTALLING THE SEAL apply a thin coat grease on the seal face.

IMPORTANT: Do not install any seal without break-in lubricant protection.

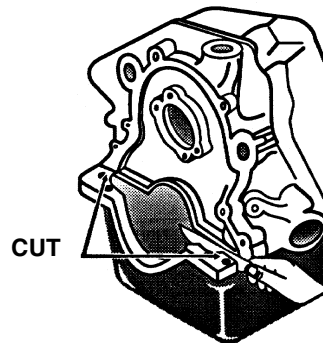

AFTER REMOVING TIMING COVER, CUT EXPOSED ENDS of the oil pan gasket flush with the cylinder block using a sharp blade, remove front oil pan end seal.

CLEAN MATING SURFACES of all foreign material including old gaskets, RTV and oil. You may wish to use a degreaser.